

Hosted by
KaiNexus

Leveraging Psychology for Effective Behavioral Change with Process Gemba Walks



Host: Mark Graban
Senior Advisor, KaiNexus
Mark@KaiNexus.com



Guest: Tracy O'Rourke
Co-founder, Just-in-Time Cafe

Webinar Logistics

- Presentation (40 minutes)
- Q&A (15 minutes)
 - Use the Zoom Webinar meeting panel to submit a question at any time

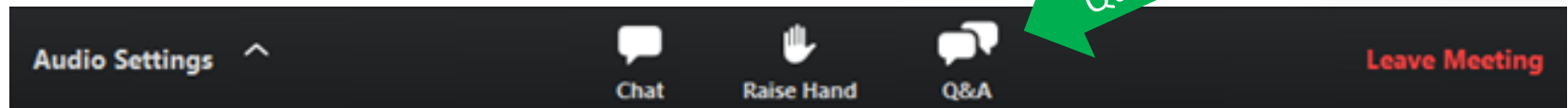
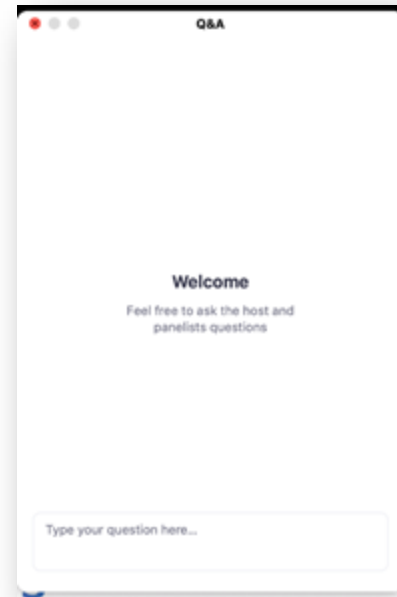

- Recording link & slides will be sent via email

KaiNexus.com

Optimize Your Improvement Work.

KaiNexus is the solution for your Lean and Improvement work where teams can capture, implement, measure, and share in one system that does it all.

▶ Watch Demo

Get Started



About Tracy O'Rourke



- Co-Founder of the Just-in-Time Cafe
- Lean Six Sigma Master Black Belt
- Co-author of "The Problem-Solver's Toolkit"
- Co-Host of the Just-in-Time Cafe Podcast,
- Lean Six Sigma Instructor at UC San Diego
- Lean Six Sigma Parody Music Video Creator

Learning Objectives

- Discover some helpful behavioral change psychology
- Recognize why Gemba Walks are effective change tools
- Practice applying the change psychology methods to different kinds of changes



The Happiness Hypothesis

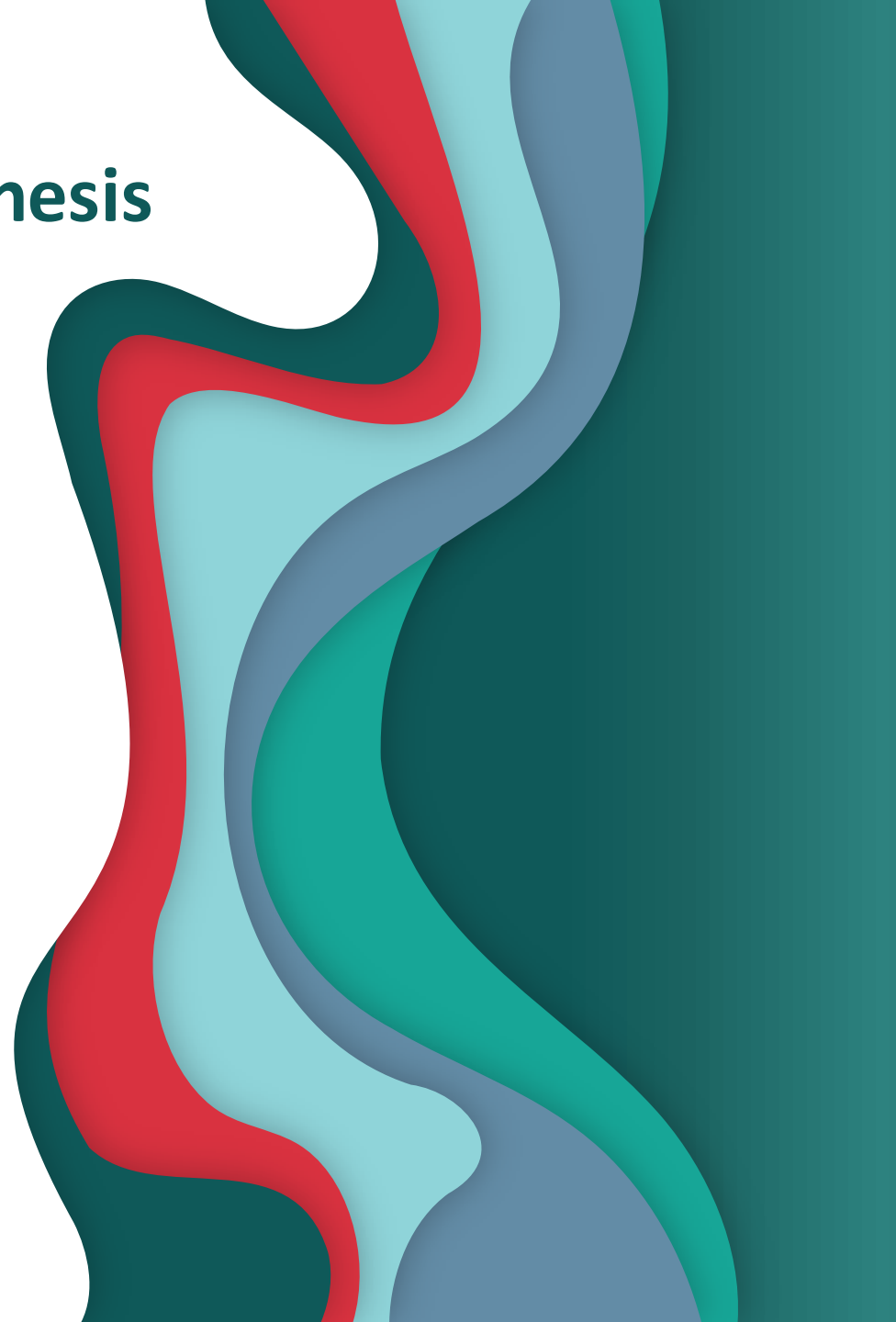
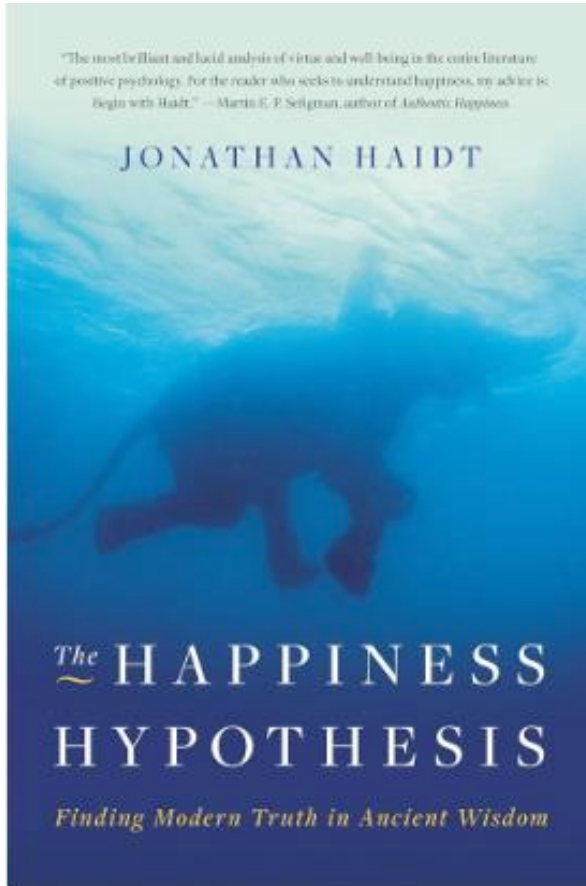

The Rider and the Elephant Analogy



Switch



Brain Psychology

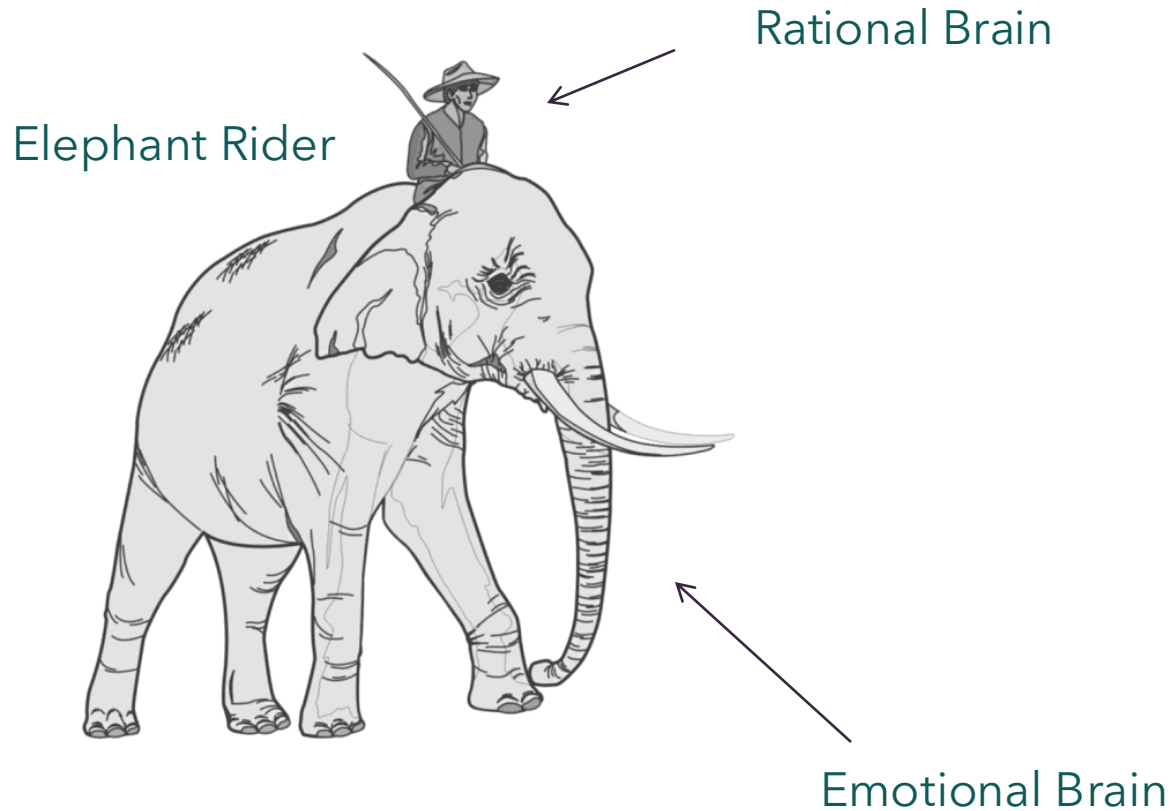

When there is a disagreement, who wins?



Rider and Elephant Challenging Qualities

Rider: Rational side of the brain

- Analytical decision-making
- The “analyzer”
- A wheel spinner
- Rational
- The rider can get his way temporarily, (willpower) but without an enlisted elephant, it will be exhausting

Elephant: Emotional side of the brain

- Emotional decision-making
- Easily spooked
- Harder to motivate
- The “do-er”
- Constantly looks to the herd for cues



Steps for Making Change Easier

- **Direct the Rider**
 - Find the Bright Spots
 - Script the Critical Moves
 - Point to the Destination
- **Motivate the Elephant**
 - Find the Feeling
 - Shrink the Change
 - Grow Your People
- **Shape the Path**
 - Tweak the Environment
 - Build Habits
 - Rally the Herd
 - Keep the Switch Going

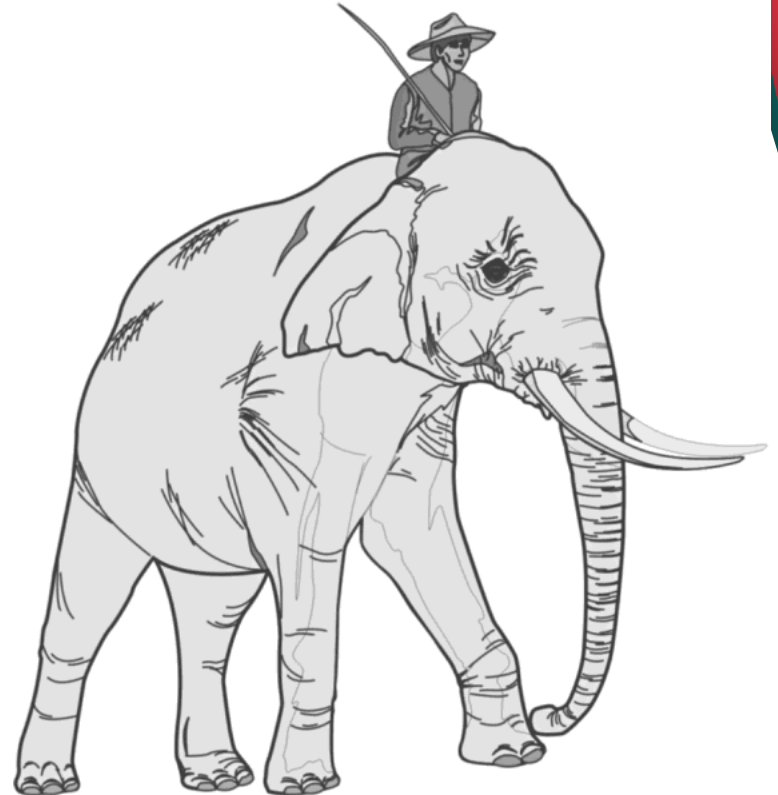

Motivate the Elephant

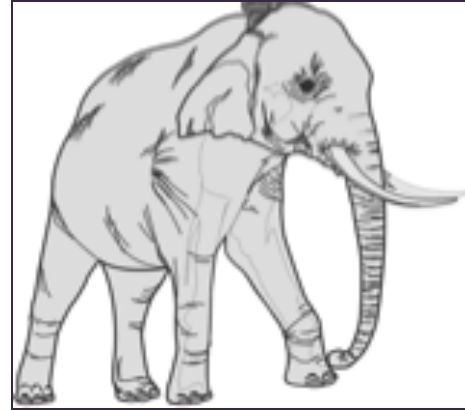

- **Find the Feeling**

- A gut-level emotional connection
- Make people feel something

- **Shrink the Change**

- Breakdown the change until it no longer spooks the elephant
- Make the change feel smaller
- Make small changes that lead to big change

- **Grow Your People**

- Make the change feel smaller by making people grow bigger
- Make change a matter of identity or self-image



How Change Occurs

How People Think
Change Occurs



How Change
Really Occurs



Drink 1% Milk Campaign



Speaking to
the Rider



Speaking to
the Elephant

Whole Milk			
Serving Size 8 fl oz (240mL)			
Servings Per Container 2			
Amount Per Serving			
Calories 150		Calories from Fat 70	
<small>% Daily Value*</small>			
Total Fat 8g			12%
Saturated Fat 5g			25%
Cholesterol 35mg			12%
Sodium 125mg			5%
Total Carbohydrate 12g			4%
Dietary Fiber 0g			0%
Sugars 11g			
Protein 8g			
Vitamin A 6%		• Vitamin C 4%	
Calcium 30%		• Iron 0% • Vitamin D 25%	
<small>* Percent Daily Values are based on a 2,000 calorie diet. Your daily values may be higher or lower depending on your calorie needs.</small>			
		Calories: 2,000	2,500
Total Fat	Less than	65g	80g
Sat Fat	Less than	20g	25g
Cholesterol	Less than	300mg	300mg
Sodium	Less than	2,400mg	2,400mg
Total Carbohydrate		300g	375g
Dietary Fiber		25g	30g

Nonfat Milk			
Serving Size 8 fl oz (240mL)			
Servings Per Container 2			
Amount Per Serving			
Calories 80		Calories from Fat 0	
<small>% Daily Value*</small>			
Total Fat 0g			0%
Saturated Fat 0g			0%
Cholesterol less than 5mg			1%
Sodium 130mg			5%
Total Carbohydrate 12g			4%
Dietary Fiber 0g			0%
Sugars 11g			
Protein 8g			
Vitamin A 8%		• Vitamin C 4%	
Calcium 30%		• Iron 0% • Vitamin D 25%	
<small>* Percent Daily Values are based on a 2,000 calorie diet. Your daily values may be higher or lower depending on your calorie needs.</small>			
		Calories: 2,000	2,500
Total Fat	Less than	65g	80g
Sat Fat	Less than	20g	25g
Cholesterol	Less than	300mg	300mg
Sodium	Less than	2,400mg	2,400mg
Total Carbohydrate		300g	375g
Dietary Fiber		25g	30g

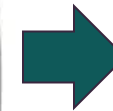

ONE glass of
whole milk has
as much fat as
5 slices of
bacon!



**Drink 1%
milk
instead!**



Volunteer Work



30lbs of carrots



Help feed 50 families



School Speed Limit



Safety



What is a Process (Gemba) Walk?

Process Walks involve going to where the work takes place and interviewing process participants to build understanding of the process.



Involve process participants to walk the process and interview each other.



Build profound knowledge of the process and root causes of problems.



Identify potential countermeasures and share with the group.



Why Walk A Process?

What You *Think* It Is...

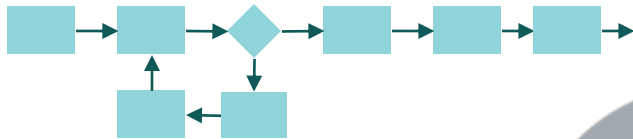

What It *Truly* Is..

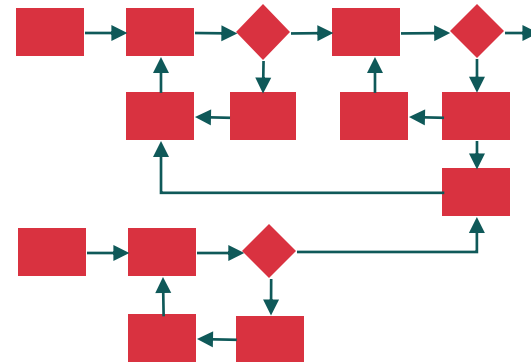

What It *Should* Be...



What It *Could* Be...



**Walking a process uncovers
the *true* process**



Some Processes Are Invisible



Do You See A Process?



Process Design Over Time



Process Walks Motivate the Elephant

Find the Feeling



I make it difficult for others downstream!?

There are so many steps in this part of the process!?

So many forms and so time-consuming!



Motivate the Elephant

- **Find the Feeling**

- A gut-level emotional connection
- Make people feel something

- **Shrink the Change**

- Breakdown the change until it no longer spooks the elephant
- Make the change feel smaller
- Make small changes that lead to big change

- **Grow Your People**

- Make the change feel smaller by making people grow bigger
- Make change a matter of identity or self-image

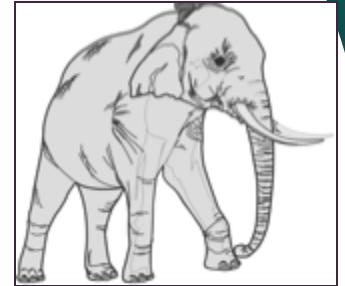

Shrink the Change: Jump Start Change

- A local car wash
- Loyalty Card Program
- Get a stamp every visit
- When the card is filled up, a free car wash



Get a blank card with 8 stamps to fill

Get a card with 10 stamps to fill, but you get two stamps when they give you the card

*6 months later, 19% of 8-stamp earned a free wash
34% of the head-start group earned a free wash (and faster)*



Shrink the Change: Set Small Goals

• Money Snowball

- List all debts from smallest to largest
- Make the minimum payments to all and send the rest to the lowest debt on the list
- The snowball: With each debt that is conquered, the “snowball” of money applied to the next debt grows and rolls a little faster
 - No discussion of interest rates make financial advisors cringe



**Changes can be small and trivial,
but the elephant is moving**



Motivate the Elephant

- **Find the Feeling**

- A gut-level emotional connection

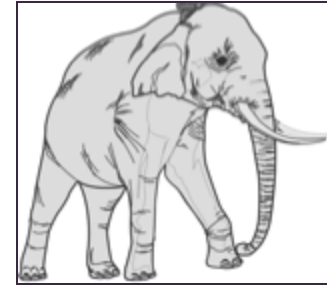

- **Shrink the Change**

- Make the change feel smaller
- Big change comes from a succession of small changes

- **Grow Your People**

- Make the change feel smaller by making people grow bigger
- Make change a matter of identity or self-image



Two Decision Making Models

*According to: James March, A Professor at Stanford University,
People rely on two basic decision-making models:*

Consequences Model

Weigh cost vs. benefit
Rational and analytical

Ask:

What is the
cost vs. the benefit?

Identity Model

Adopted set of beliefs that
define who you are
(personal and professional identities)

Ask:

What would someone like me
do in this situation?



Motivate the Elephant

- **Identity Model:** Make change a matter of identity or self-image
 - We can be born with identities or adopt identities (religion, role, politics, career)
 - Three Questions are asked:
 - Who am I?
 - What kind of situation is this?
 - What would someone like me do in this situation?

What happens when you attempt a change that goes against people's identity?



Identity Model



MENLO
innovations



Call To Action

- **Identify a personal application for “Motivate the Elephant” and find the feeling, shrink the change, or grow yourself!**
 - Cleaning the house
 - Working out
 - Eating better
- **Apply the concept “Motivate the Elephant” to change efforts at work**
 - Improve the “change” message
 - Conduct Process Walks for improvement



Application 1: Applying Motivate the Elephant

- A university head needs departments to reduce budgets by 5%. Most of them understand and agree with the need to cut back, but there is a danger of people dragging their heels

Apply Motivate the Elephant:

Find the feeling
Shrink the change
Grow your people

**How do you apply
“Motivate the Elephant” concepts?**



Application 2: Applying Motivate the Elephant

- Developers responsible for writing new programs fell in love with their code.
- When their program was tested by customers, they say, “Who selected the idiots to test?”

Apply Motivate the Elephant

Find the feeling
Shrink the change
Grow your people

**How do you apply
“Motivate the Elephant” concepts?**



Summary: Motivate the Elephant

- **Find the Feeling**

- A gut-level emotional connection

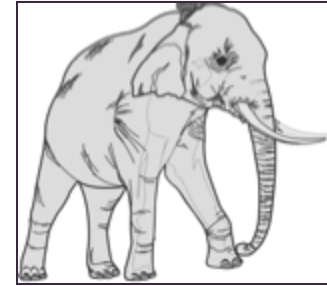

- **Shrink the Change**

- Make the change feel smaller
- Big change comes from a succession of small changes

- **Grow Your People**

- Make the change feel smaller by making people grow bigger
- Make change a matter of identity or self-image



What We Covered

- Discover some helpful behavioral change psychology
- Recognize why Gemba Walks are effective change tools
- Practice applying the change psychology methods to different kinds of changes



GET YOUR FREE POSTERS



Free
Flyers



Baby Got Tools
Music Video



5S Baby!



5S Poster



8 Wastes Poster





Just-in-Time *Cafe*

THANK YOU!!



Tracy O'Rourke

Connect with me on LinkedIn: [linkedin.com/in/tracy-orourke](https://www.linkedin.com/in/tracy-orourke)

E-mail: Tracy@jitcafe.com

Websites

www.tracyaorourke.com

www.jitcafe.com

KaiNexus

Why KaiNexus?

Solutions

Features

Resources

Pricing

Get Started

Register or get notified of future webinars: www.KaiNexus.com/webinars

KaiNexus Webinars

**NEXT WEBINAR:
TBD**



blog.kainexus.com

KaiNexus

[Why KaiNexus?](#)

[Solutions](#)

[Features](#)

[Resources](#)

[Pricing](#)

[Get Started](#)



6 Solutions for Overcoming Improvement Challenges

June 1, 2023

For organizations of all types, continuous improvement is vital for building a culture of innovation, remaining competitive, ensuring...



What Is Continuous Improvement? Everything You Need to Know to Improve Your Workplace

May 31, 2023

Continuous improvement is not a one-time project or initiative; it is an ongoing continuous improvement mindset and culture that should be...



Understanding the Importance of Lean Business Process Management Software

May 25, 2023

Kainexus Logo

Companies constantly seek ways to improve process efficiency and reduce waste in today's rapidly changing business landscape. One approach...



The KaiNexus Podcast

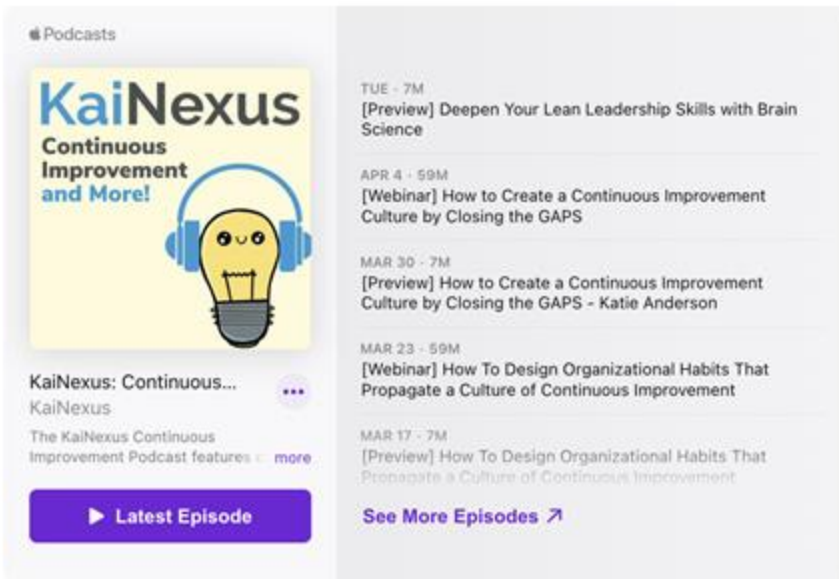

- www.KaiNexus.com/podcasts
- Subscribe via:
 - Apple Podcasts
 - Overcast
 - Stitcher
 - Other apps & services

